

# John Godwin Signature

## CRAPPIE TOWER *Horizontal Placement (30 lbs.)*

One 20" trunk, one 60" trunk, one 8" coupler, eight 1" screws,  
nine 46" limbs, twelve 60" limbs, one laydown cable kit



1. Insert all short (46") limbs into 20" trunk: insert one limb at a time into outer V-shape and **angle tip down slightly** as you insert into V-shape directly across trunk.
2. Secure 60" trunk to coupler with four 1" screws. Be sure the trunk is positioned upright where slits appear as "V" shapes.
3. Insert long (60") limbs into 60" trunk section.
4. Lay habitat on its side and wrap cable around trunk between limbs. Clip one quick link to secure cable. Clip the second quick link to chain around concrete block.

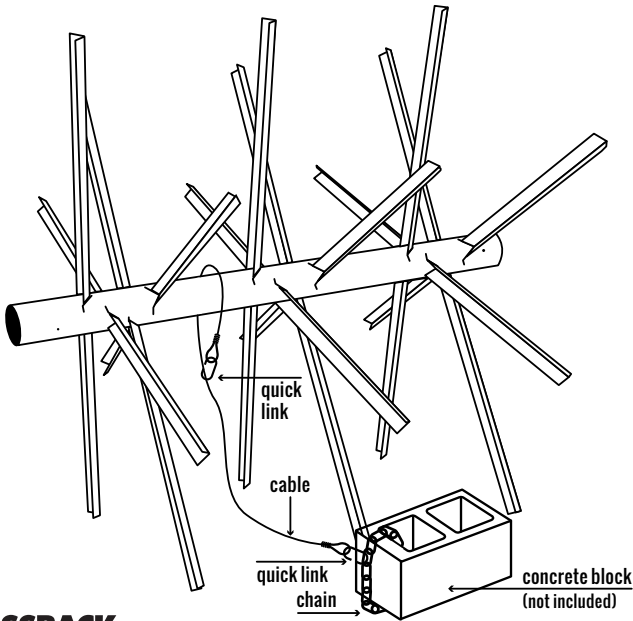
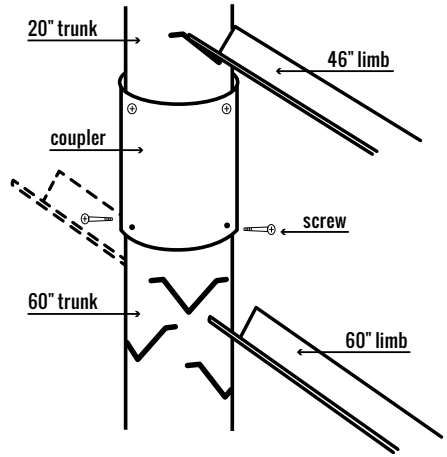

# LAYDOWN CABLE KIT (2 lbs.)

One 5' cable, two 3/16" quick links, one 24" chain



*(used for weighting of The John Godwin Signature Crappie Tower for horizontal placement)*

1. Lay habitat on its side and wrap cable around trunk between limbs.  
Clip one quick link to secure cable. Clip the second quick link to chain around concrete block.

