

# John Godwin Signature

## DOCK CRAPPIE TOWER (30 lbs.)

One 20" trunk, one 60" trunk, one 8" coupler, eight 1" screws,  
nine 46" limbs, twelve 60" limbs, one cable kit



1. Insert all short (46") limbs into 20" trunk: insert one limb at a time into outer V-shape and angle tip down slightly as you insert into V-shape directly across trunk.
2. Secure 60" trunk to coupler with four 1" screws. Be sure the trunk is positioned upright where slits appear as "V" shapes.
3. Insert long (60") limbs into 60" trunk section.
4. Wrap the chain around any part of the dock frame that is structurally sound. Secure with quick link. **Do NOT wrap the cable around the dock structure** - it can cause damage to the cable and/or your dock over time. Cable kits will add at least 5 feet of depth to your vertical product. Depending on placement, the attached chain can also add additional depth. If you want to adjust the depth, do so *only by adjusting the chain* - not wrapping the cable. Depth can also vary if the product is hung from a support that is close to or far from the water.

**IMPORTANT NOTE:** Attach product to the dock BEFORE placing it in the water.

**For deeper placement we recommend our depth extender (sold separately).**

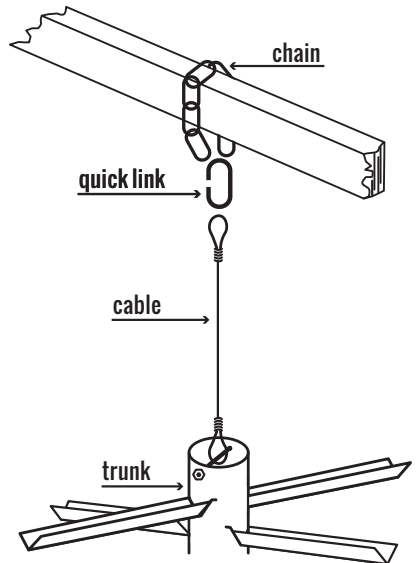
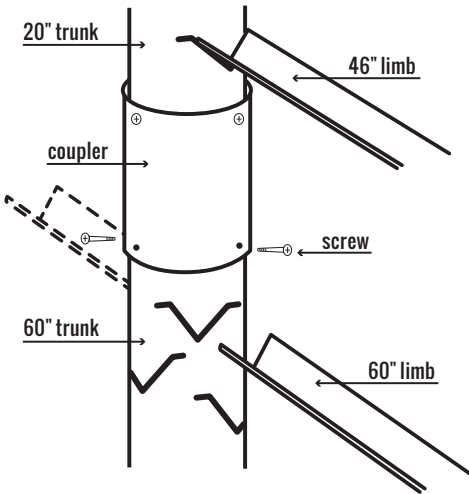

Do not place in swimming or boating areas. Check your local game laws.